

STEPPED FOOTING 23

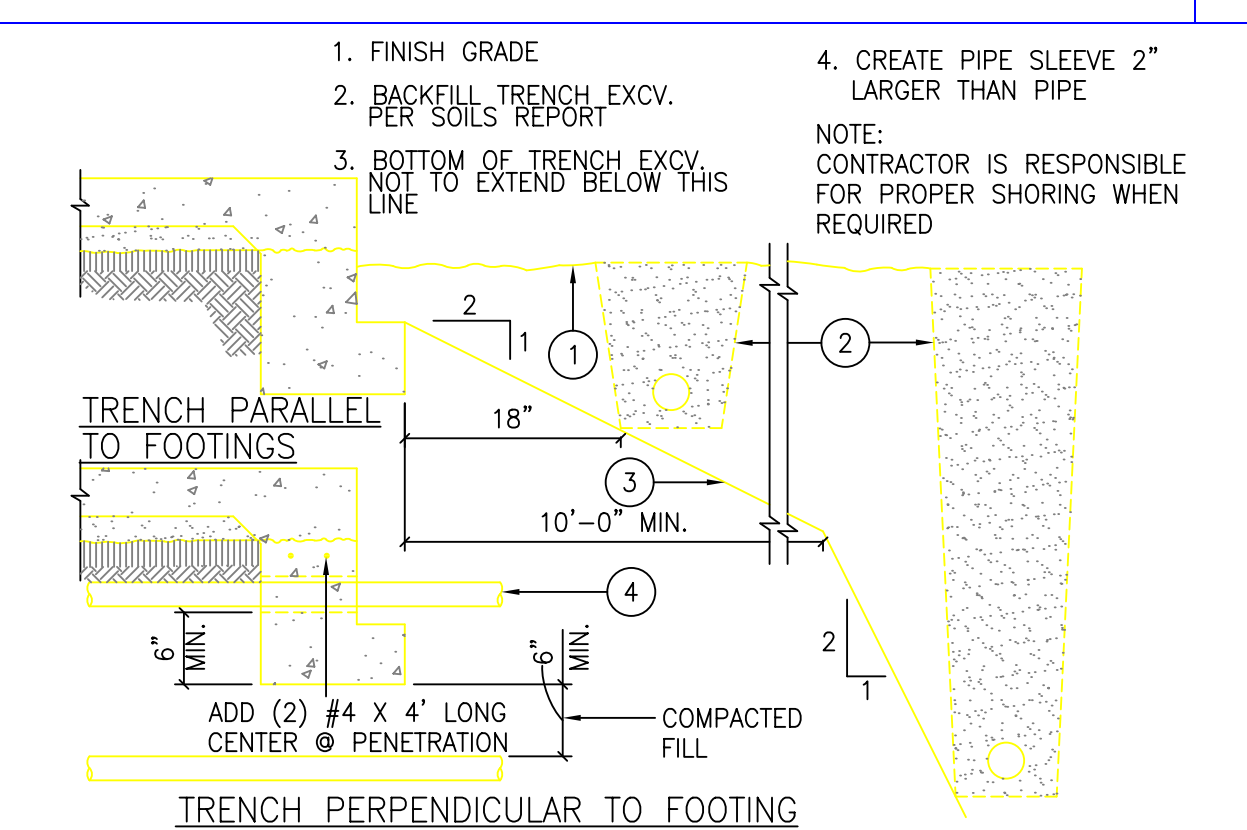

TYP. TRENCH @ FOOTINGS 24

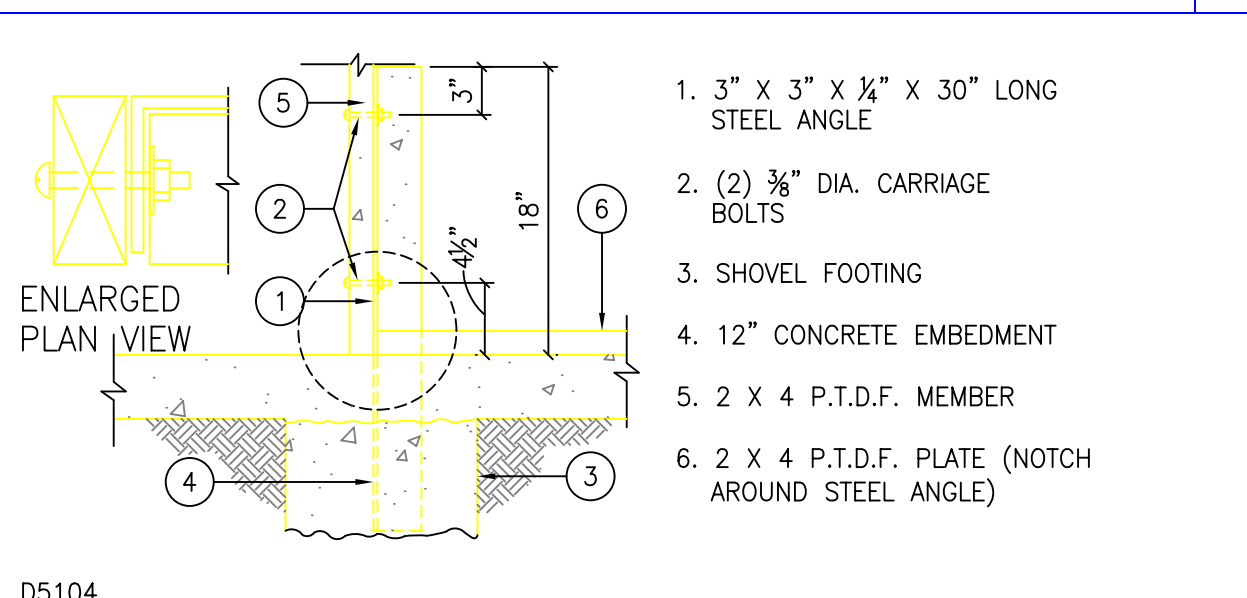

PONY WALL 25

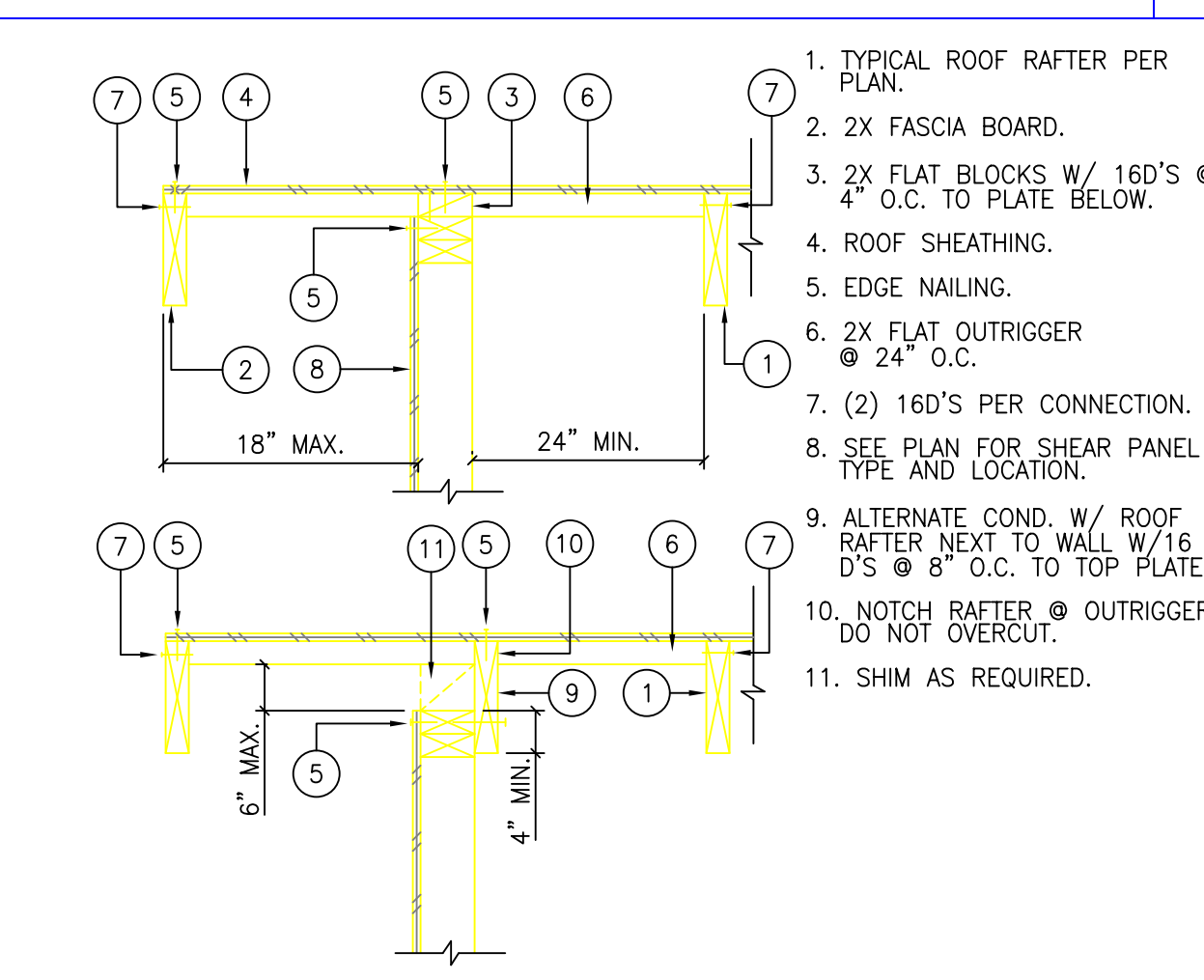

MISSING OR MISPLACED A.B. 19

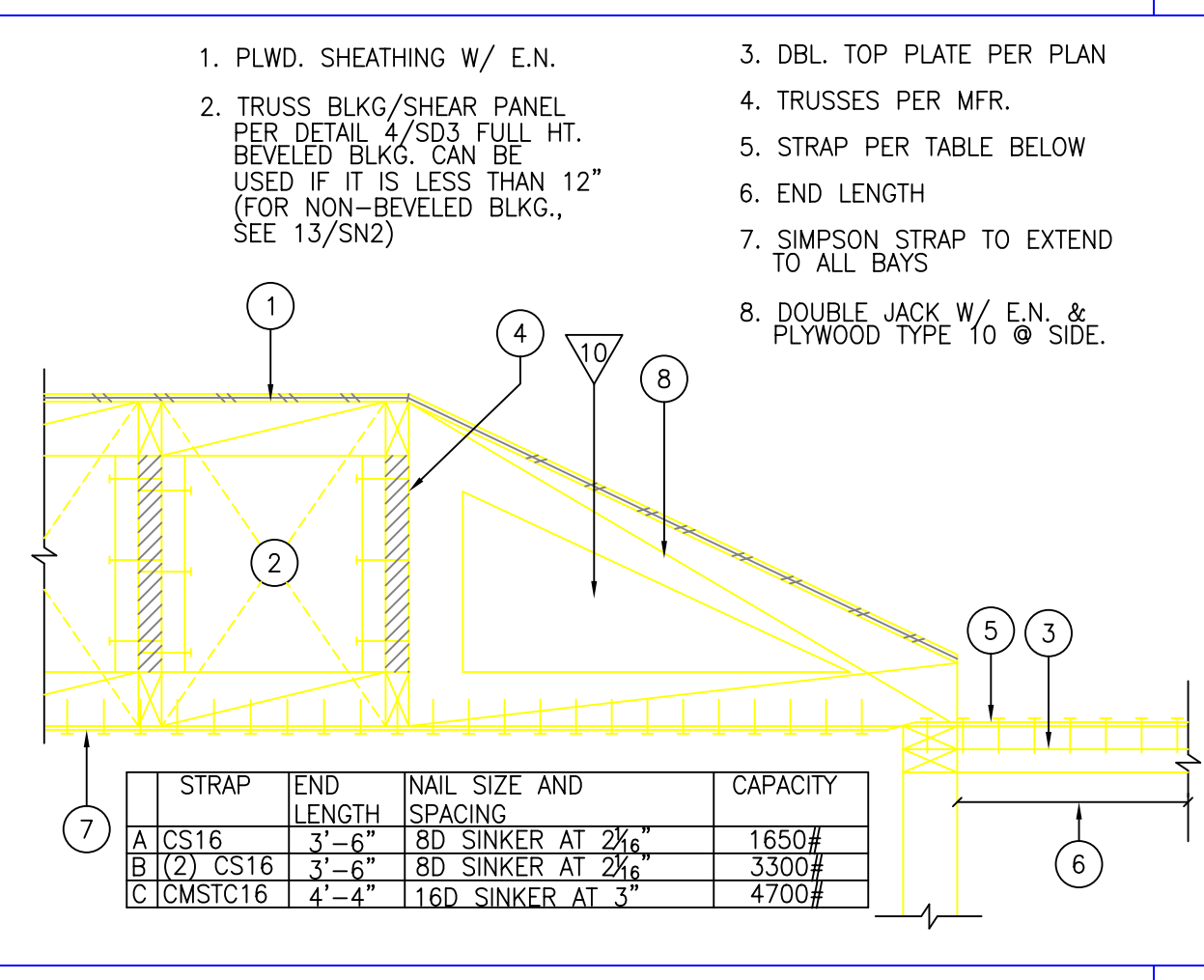

FIX FOR MISSING HOLDOWN 20

FIX FOR OVERSIZED HOLE 21

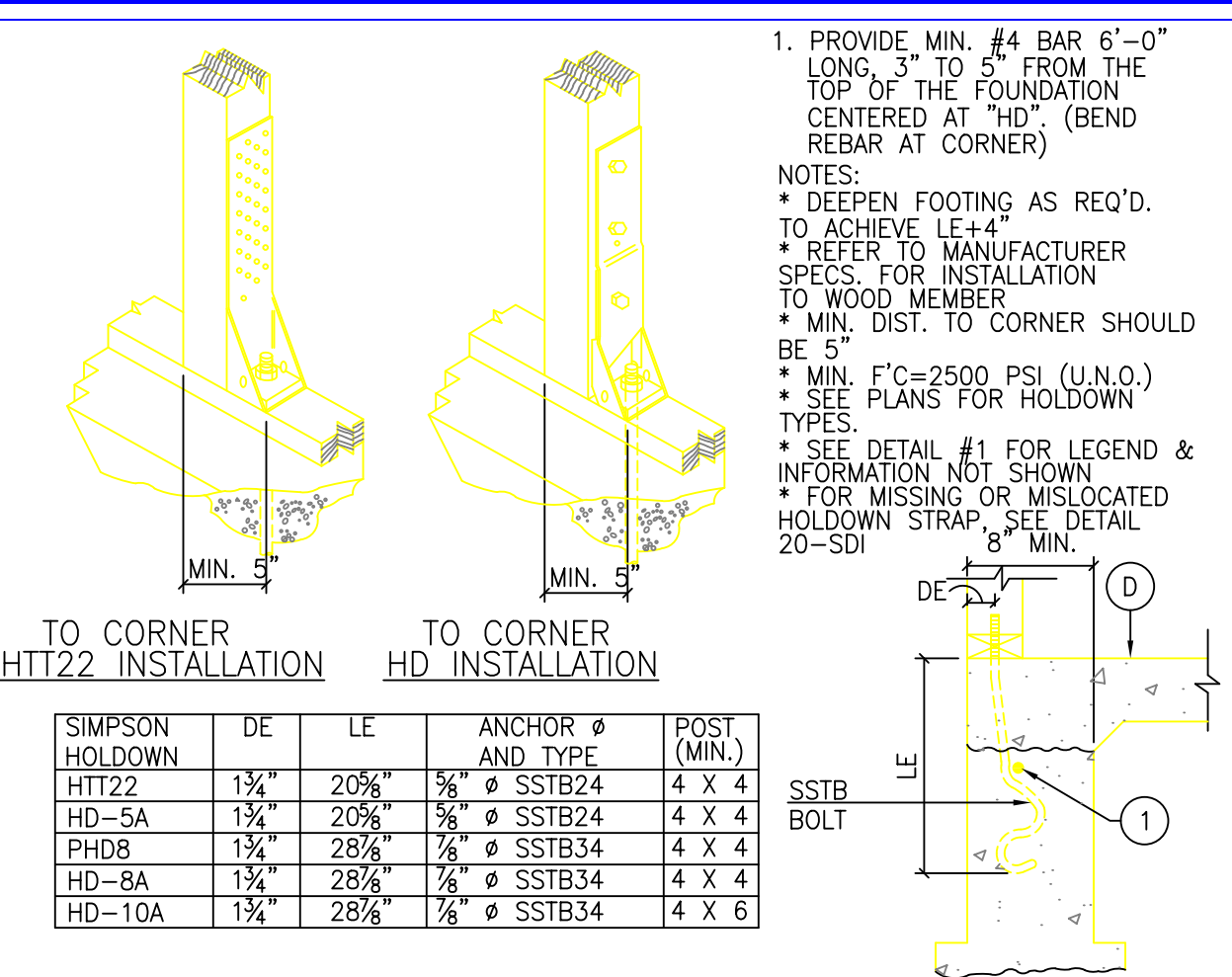

TYP. HOLDOWN INSTALLATION 18

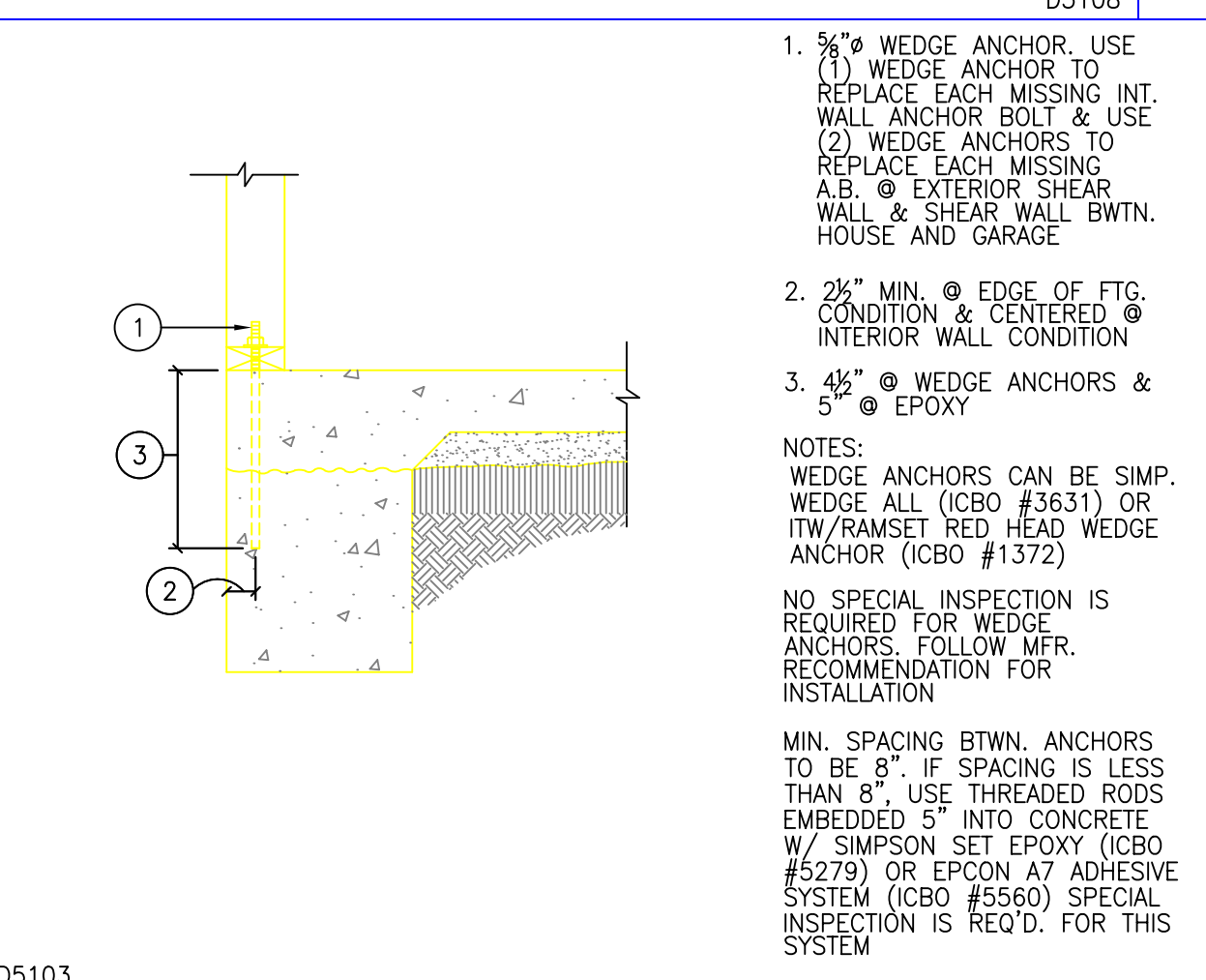

MISSING OR MISPLACED A.B. 19

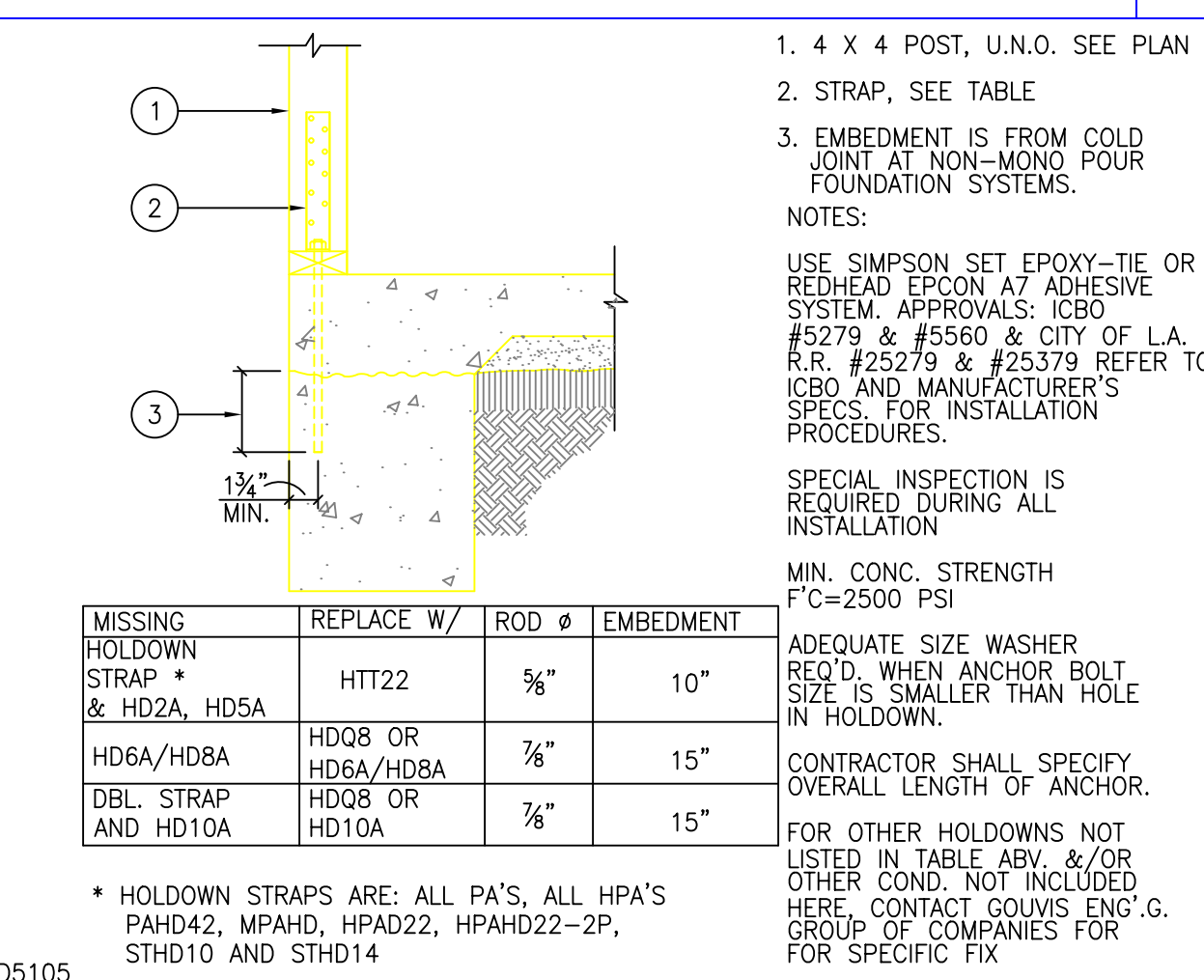

FIX FOR MISSING HOLDOWN 20

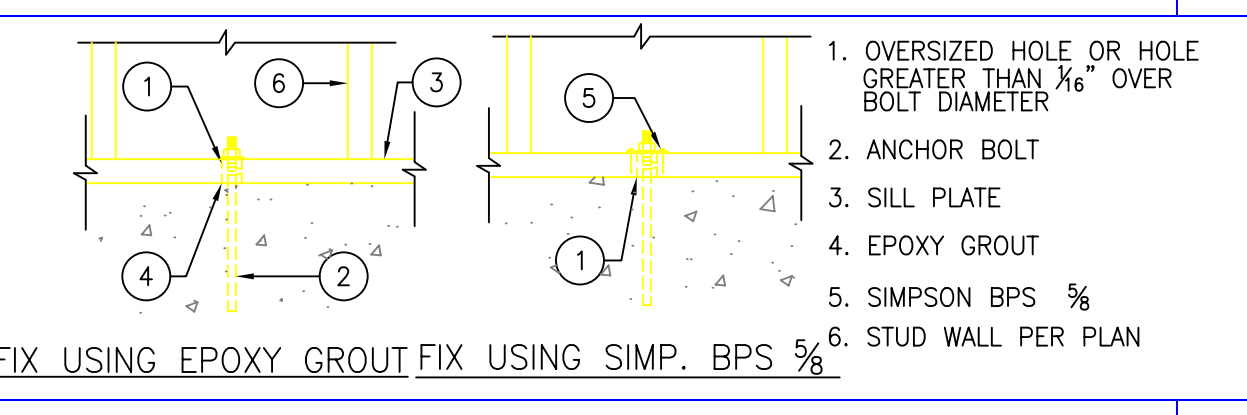

FIX FOR OVERSIZED HOLE 21

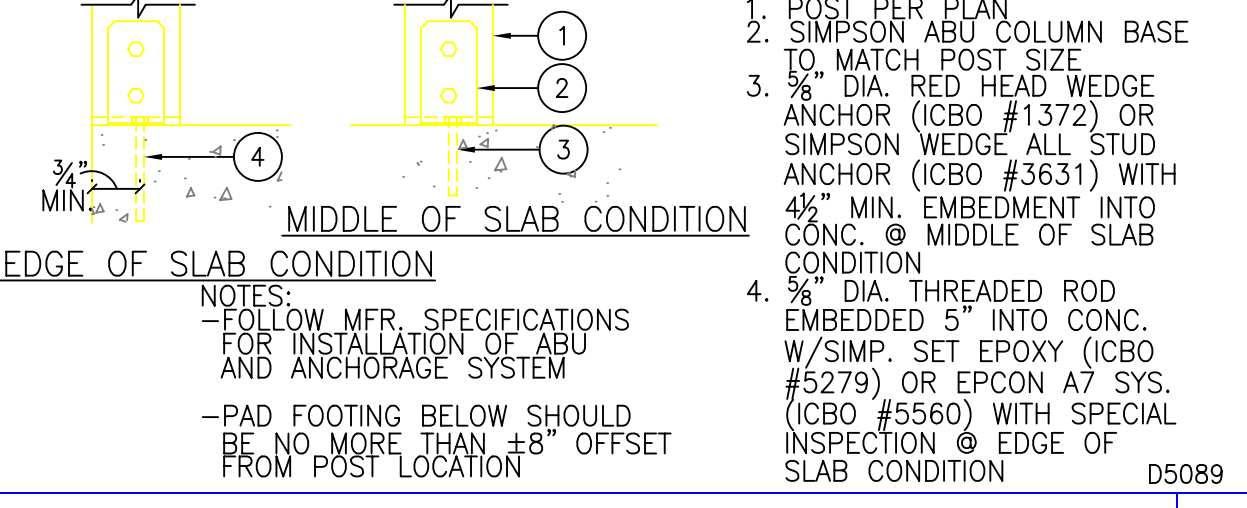

MISSING/MISPLACED COL. BASE 22

HD14A/HD15 HOLDOWN INST. 17

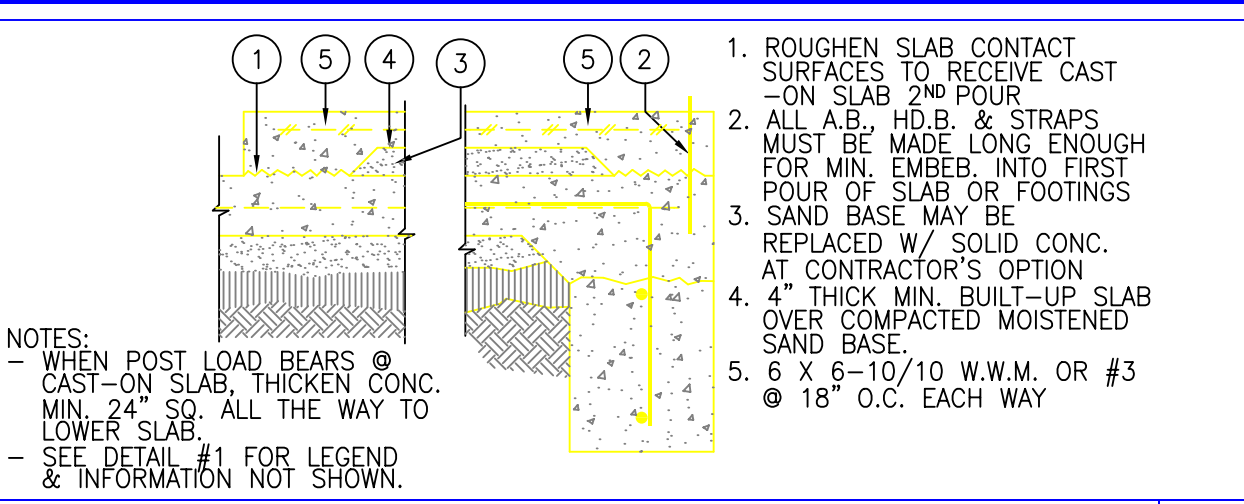

BUILT-UP SLAB 13

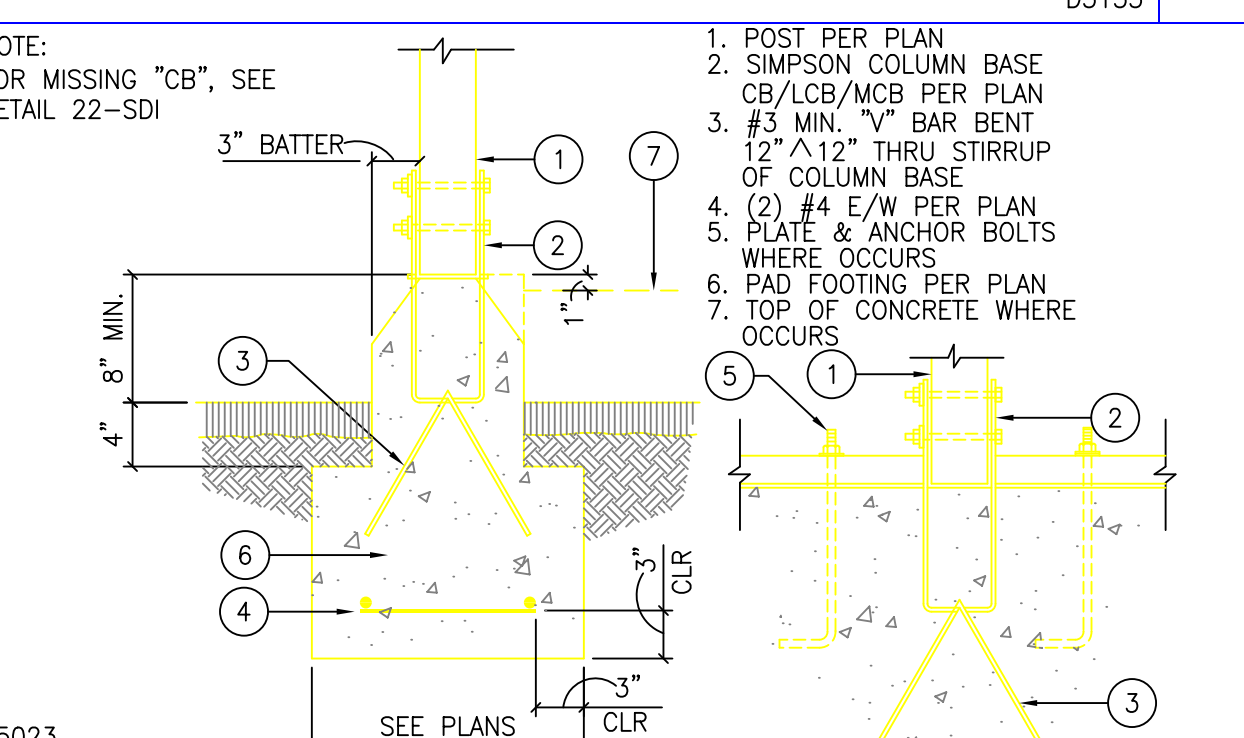

COLUMN BASE 14

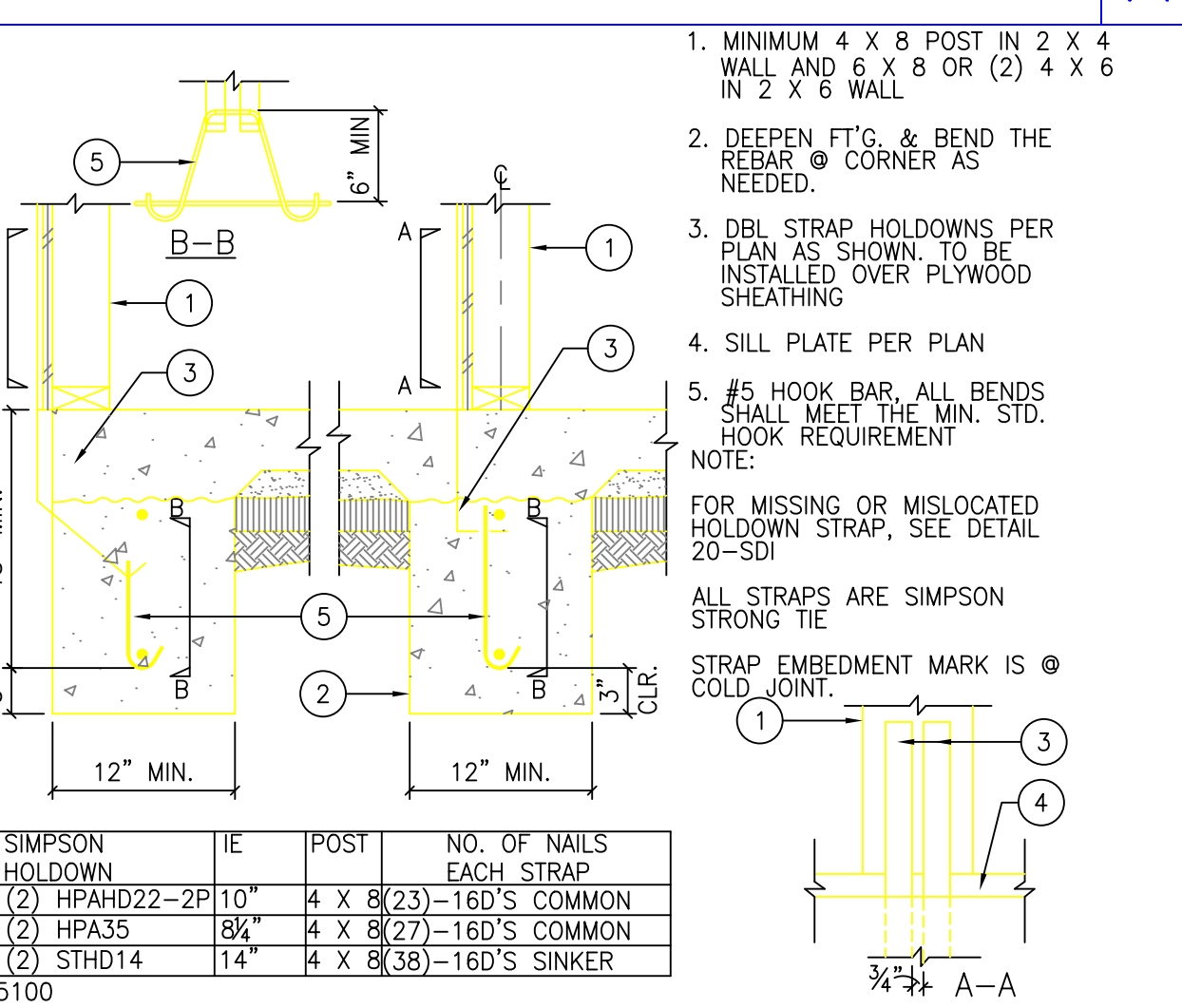

HOLDOWN STRAP 15

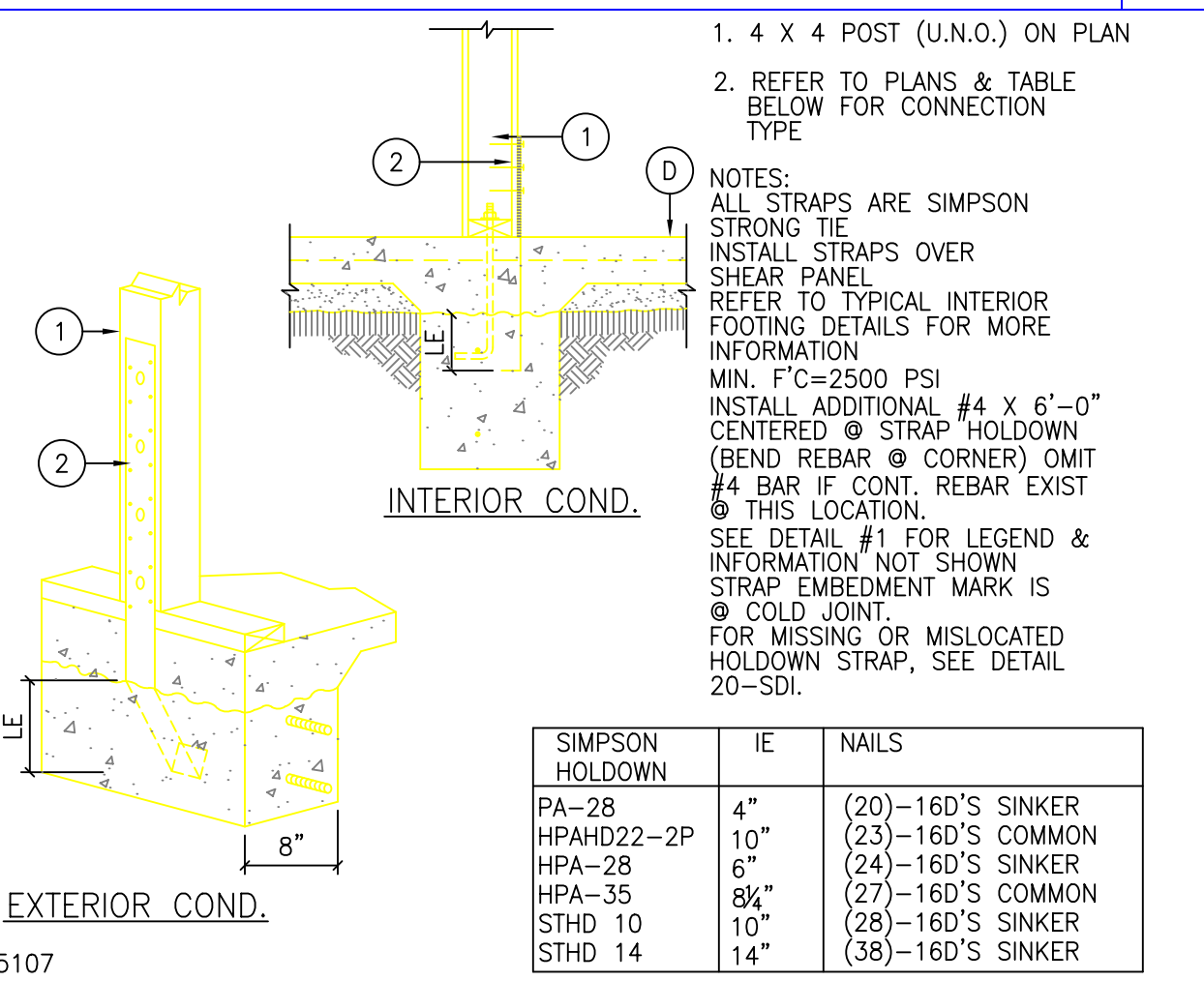

HOLDOWN STRAP 16

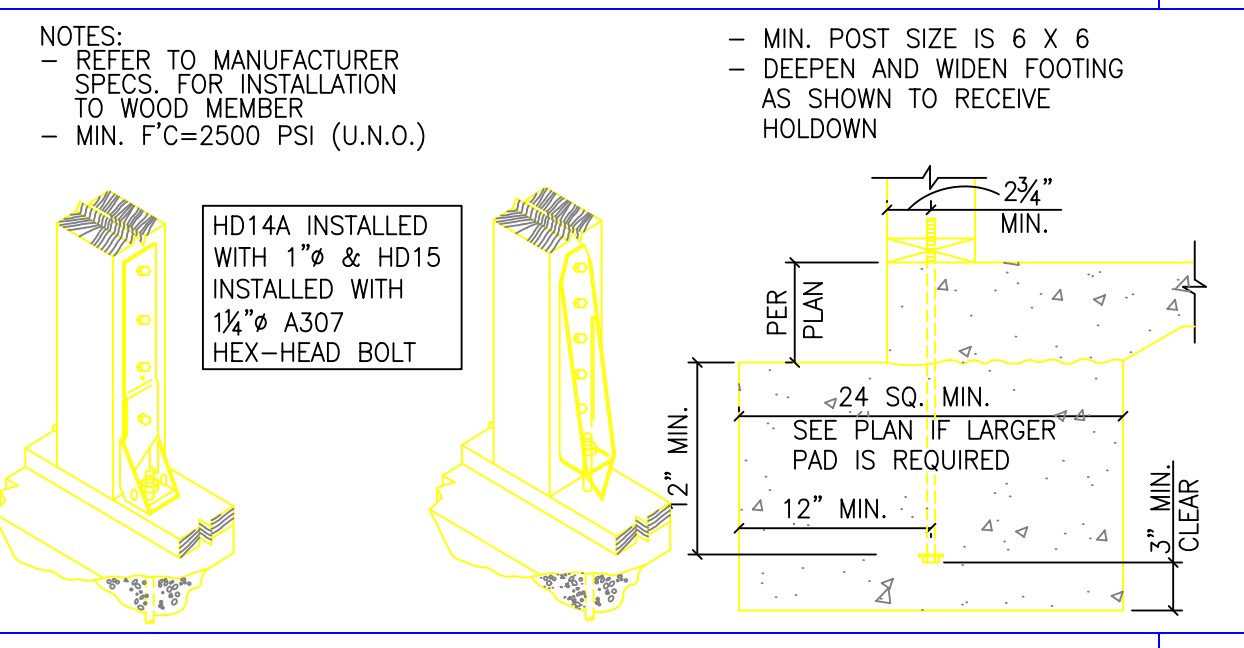

HD14A/HD15 HOLDOWN INST. 17

PIPE COLUMN 12

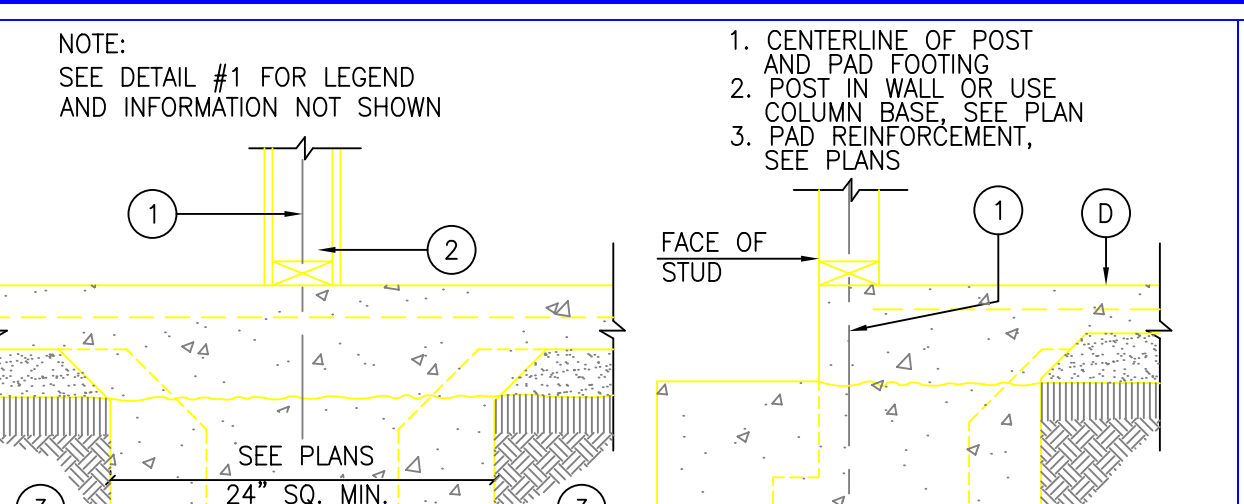

ISOLATED PAD FOOTING 6

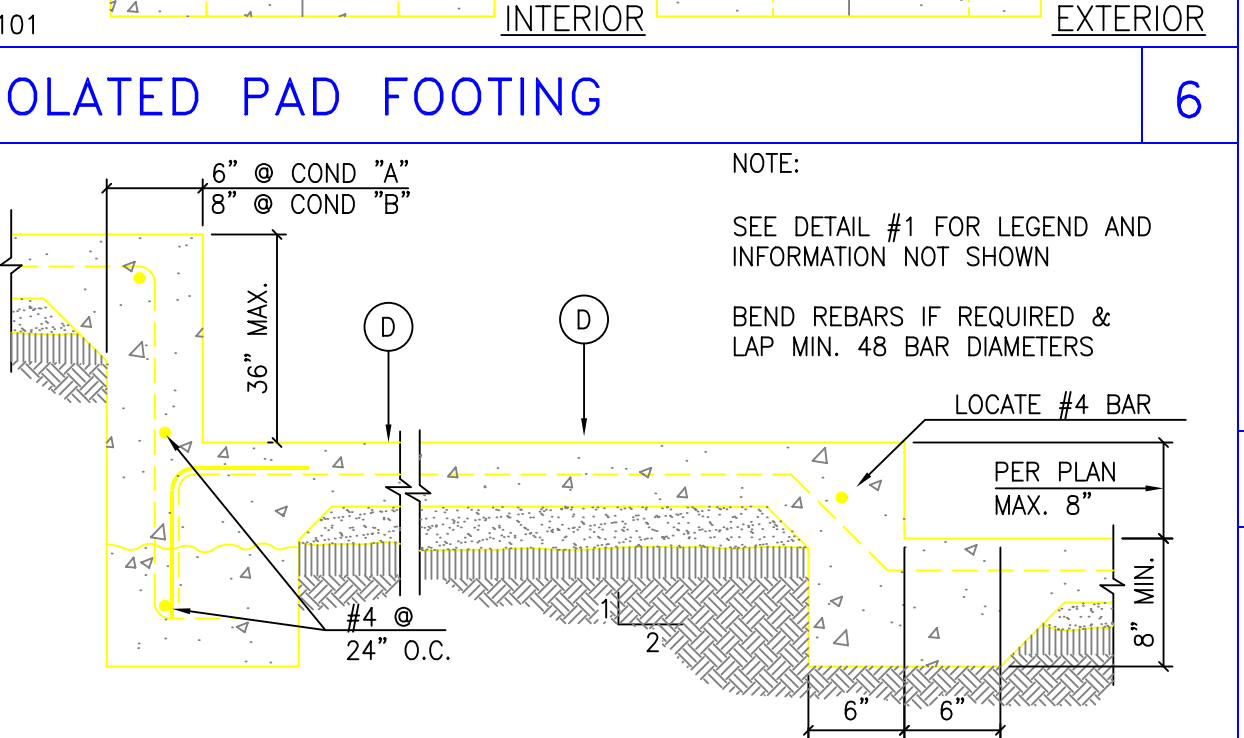

STEP AT CONCRETE SLAB 7

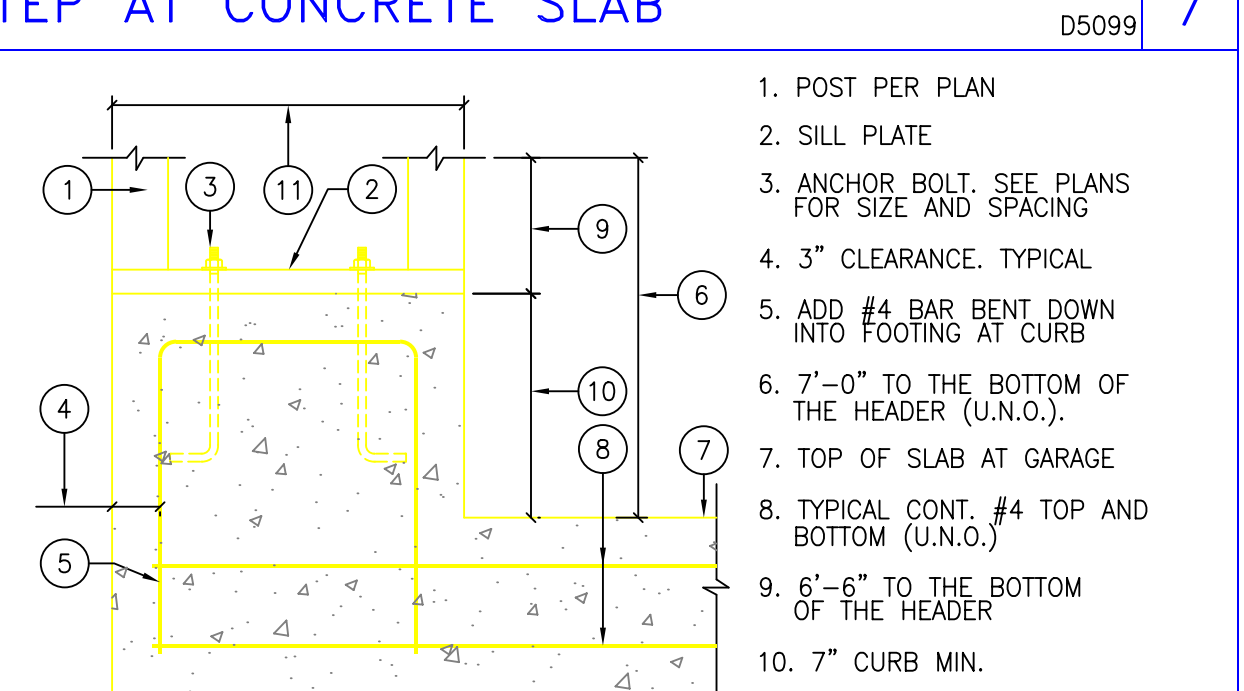

RAISED CURB 8

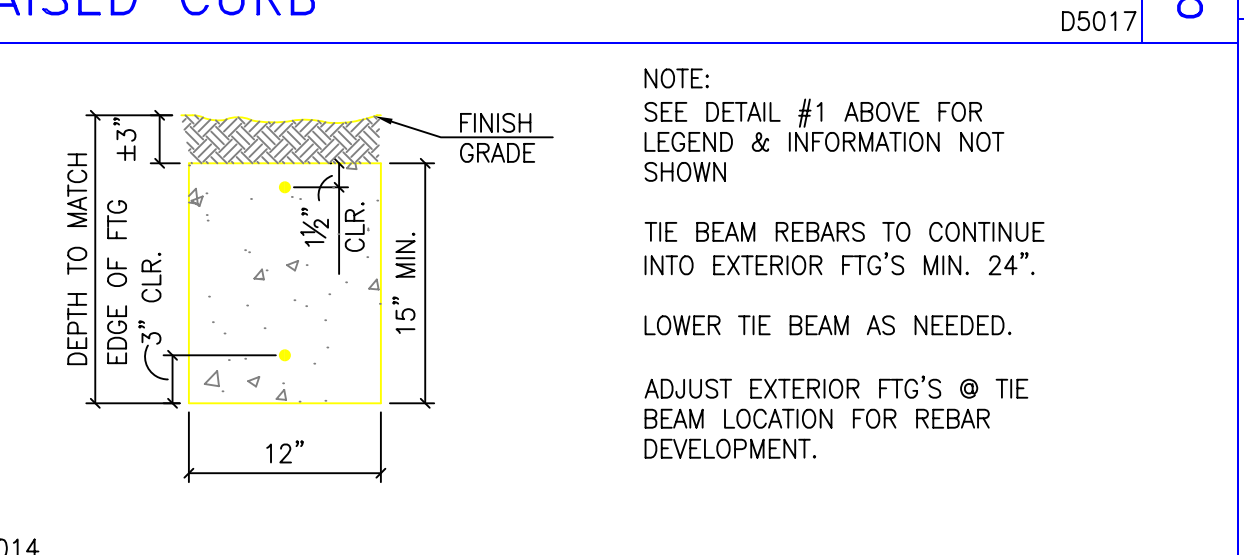

TIE BEAM 9

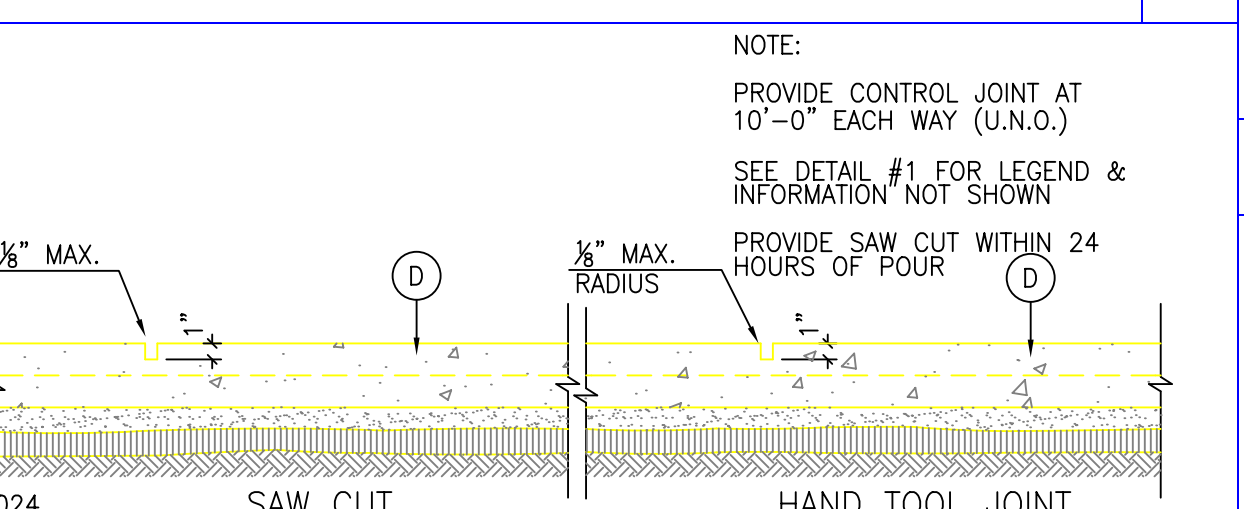

TYP. CONTROL JOINT 10

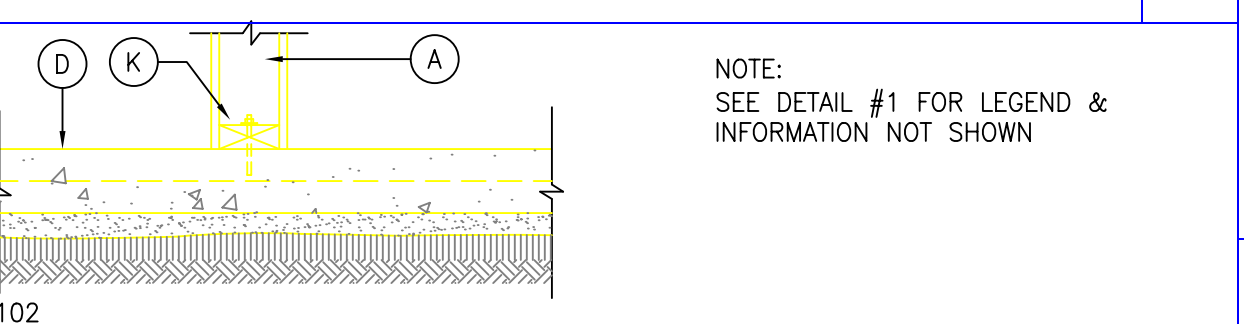

NON-BEARING INTERIOR WALL 11

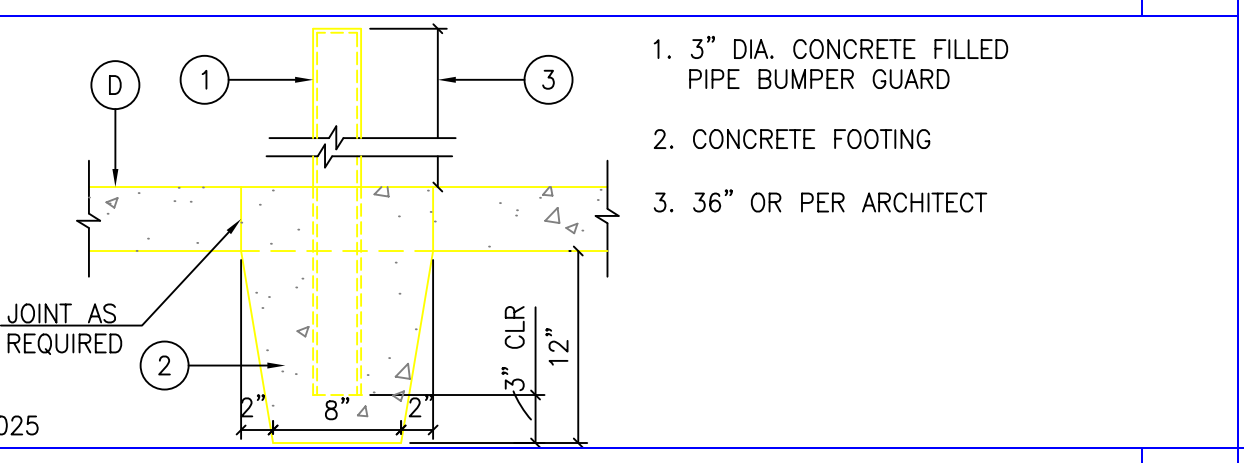

PIPE COLUMN 12

HOUSE TO PORCH 5

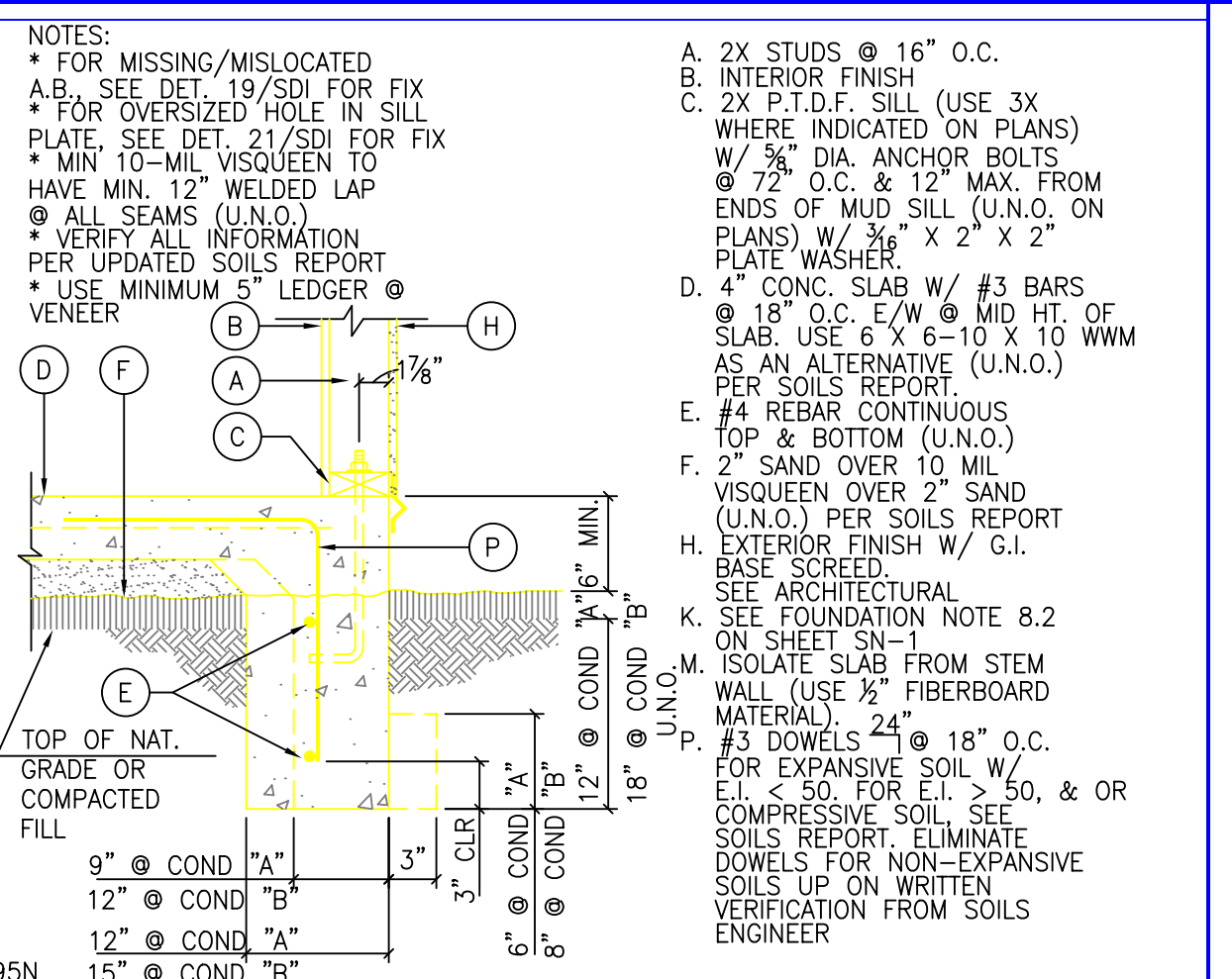

TYPICAL EXTERIOR FOOTING 1

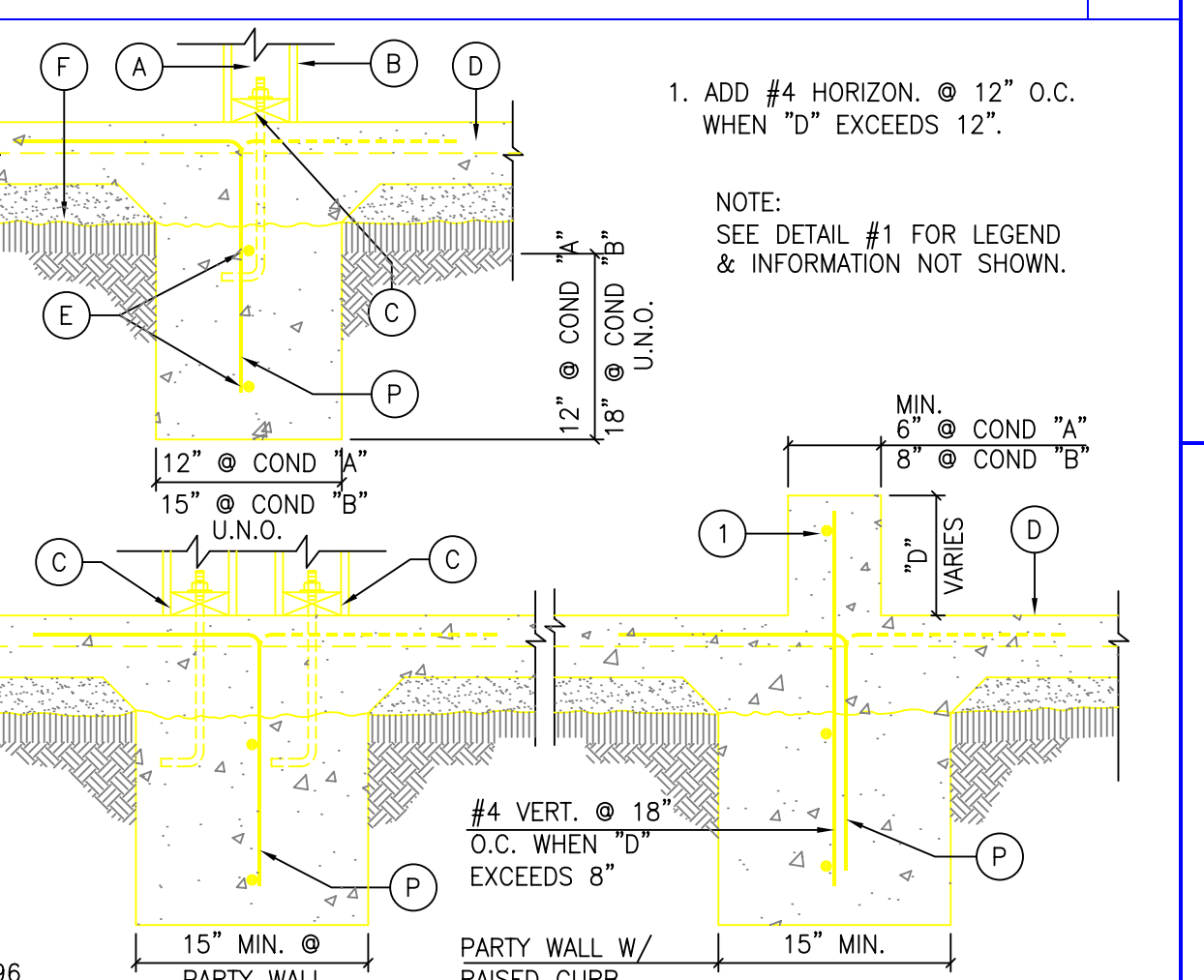

INTERIOR BEARING FOOTING 2

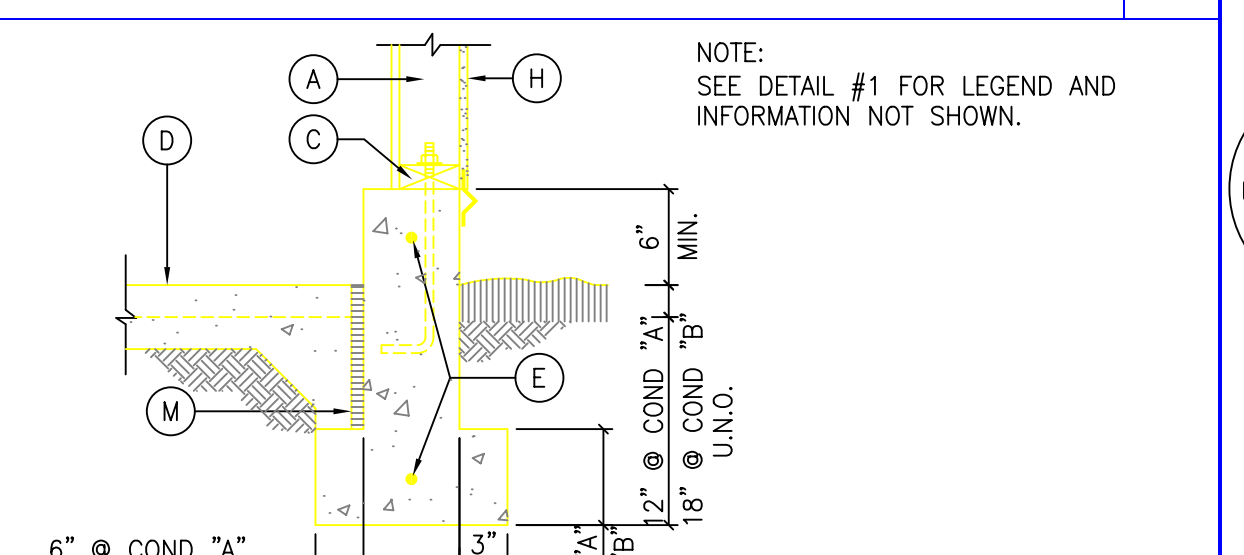

EXT. BEARING GARAGE CURB 3

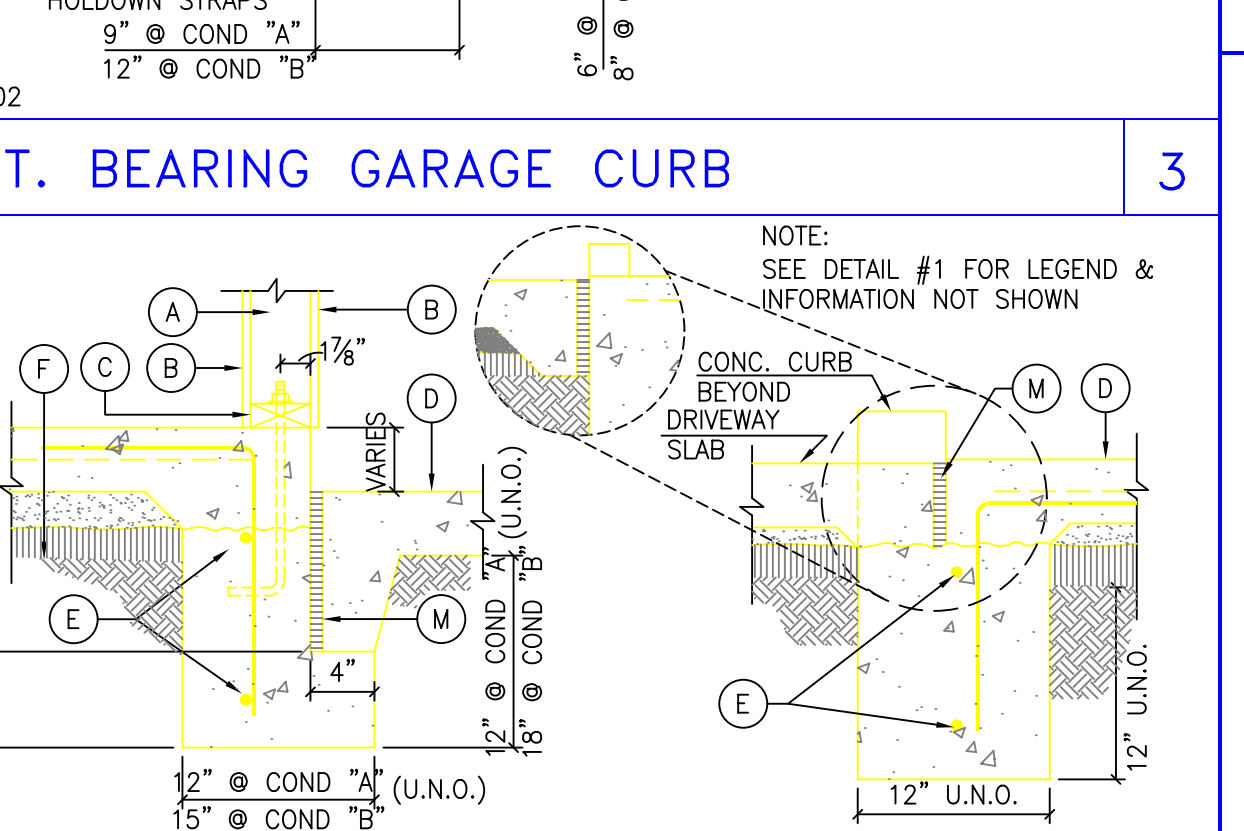

HOUSE TO GARAGE/APRON 4

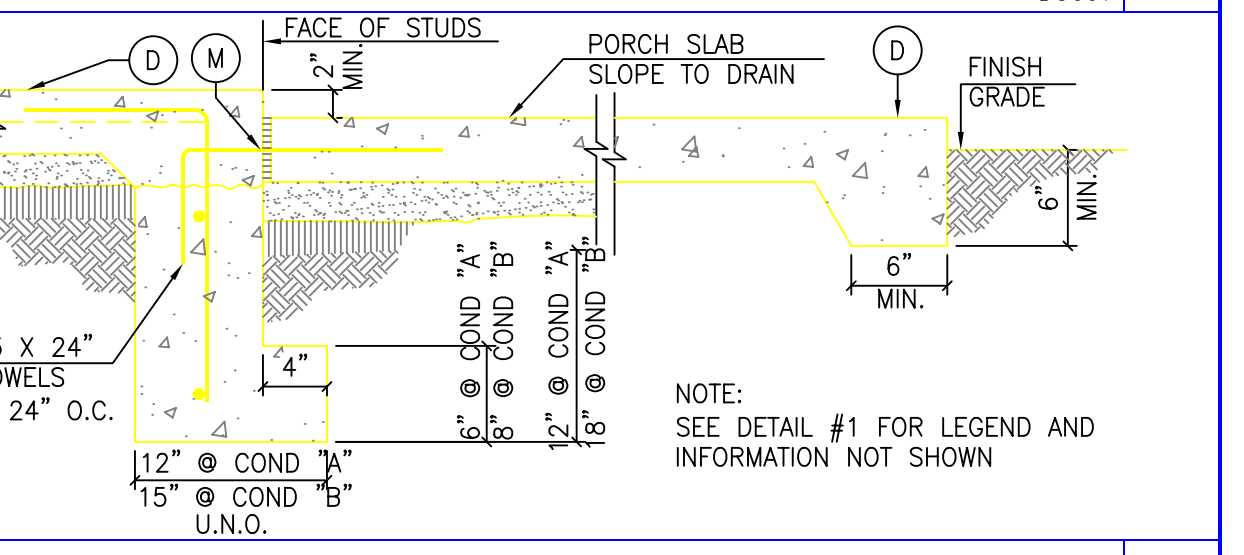

HOUSE TO PORCH 5